

Application Note AN-2201

SCALE-2 Family

Parallel Connection of SCALE-2, SCALE-iFlex and SCALE-iFlex LT Gate Drivers

Abstract

In order to overcome limited current ratings and achieve higher power capacity, IGBT power modules are increasingly connected in parallel. Ensuring collector current sharing and symmetric collector-emitter voltages between paralleled IGBTs are key challenges for the gate drivers. Power Integrations gate drivers utilizing SCALE™-2 technology (e.g. 1SP0630, 1SP0635, 1SP0340 and 1SP0335 product families) plus the SCALE-iFlex™ and SCALE-iFlex LT families address these challenges. This application note explains the paralleling concept for SCALE-2 and SCALE-iFlex / SCALE-iFlex LT gate drivers. The document also provides basic guidelines on hardware optimization for the paralleled IGBT modules themselves as the mechanical set-up also has a major impact on current distribution between parallel-connected IGBT modules.

Introduction on Paralleling

Drain current variation between paralleled IGBTs is caused by static and dynamic imbalance. If there is poor current distribution between paralleled IGBTs, one IGBT will be required to carry significantly higher current than the others, leading to lower utilization of the converter, and reduced reliability and eventual failures of overstressed IGBT.

The asymmetrical current distribution shown in Figure 1 is influenced by several factors. IGBT module characteristics (including saturation voltage, internal gate resistance and stray inductance) influences both static and dynamic current distribution. In response to this power semiconductor manufacturers offer IGBT modules for parallel connection that have matched parameters. The use of selected IGBT modules is recommended.

Common-mode disturbances to gate voltages, stray inductance and switching delay are key parameters that must also be considered when optimizing gate drivers for parallel operation. In addition, the mechanical design of the DC and AC busbars as well as cooling conditions play an important role in optimizing current distribution.

The following sections describe Power Integrations' solutions for paralleling and provide guidance for optimizing system design.

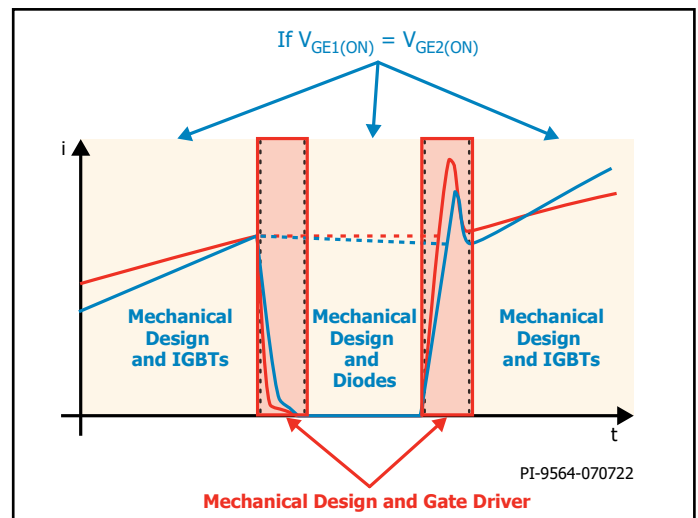

Figure 1. Controlling Factors for Current Asymmetry During Double Pulse Testing.

Parallel Connection of Main and Peripheral SCALE-2 Drivers

SCALE-2 drivers with main plus peripheral capability can be used for paralleling IGBT modules. If a parallel connection of up to four IGBT modules is required, one main driver and several peripheral drivers must be used. The basic operating principle is illustrated in Figure 2. It should be noted that the number of modules that can be paralleled depends on the driver family selected and the IGBT module used. Refer to the appropriate data sheet for more information. For 1SP0635 drivers, electrical isolation is implemented in the main driver. For the 1SP0335, 1SP0630 and 1SP0340 gate driver families, isolation is implemented via a separate DC-DC converter unit.

Electrical isolation is realized on the main board via a fiber optic interface for the input and the status feedback signals. Power for the peripheral units as well as the required signals are transferred between the peripheral and main gate drivers via the interface bus. Both X1 and X2 are identical and interchangeable on the main and peripheral drivers. The paralleling interfaces X1 and X2 ensure that the paralleled drivers switch synchronously.

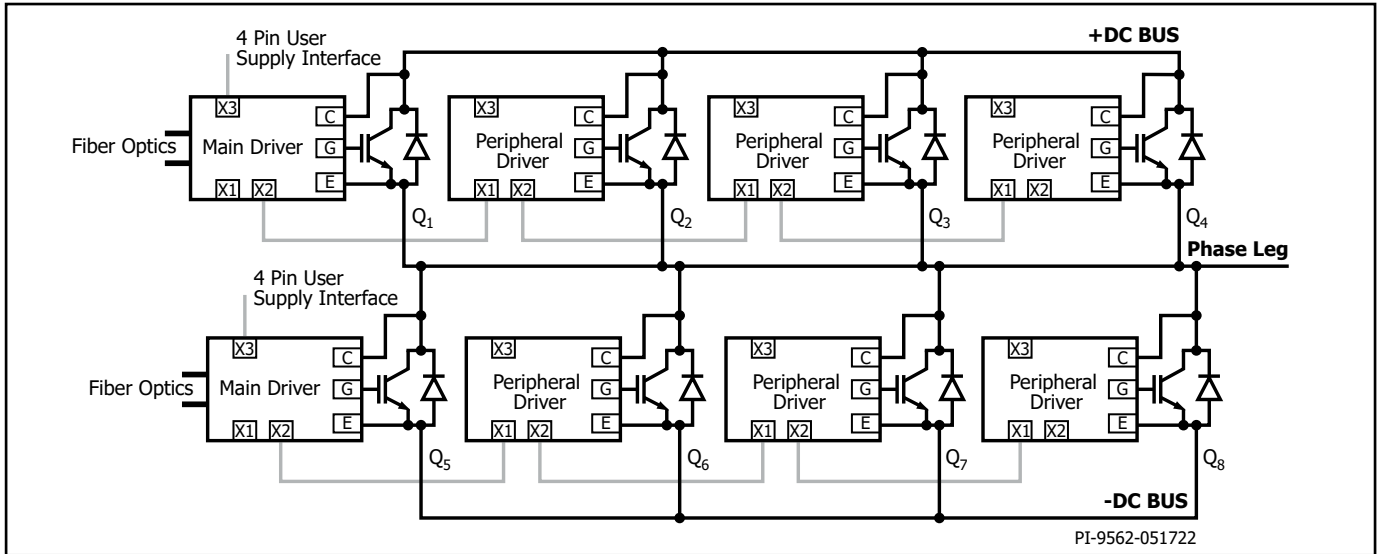

Figure 2. Parallel Connection of One Main and Three Peripheral Drivers for a Half-Bridge Configuration.

Mechanical Considerations

For symmetrical operation of paralleled gate drivers, the following points are critical:

- The converter should be constructed as symmetrically as possible with respect to the positioning of the paralleled IGBT modules. In particular stray DC-link inductance of each paralleled IGBT module should be kept the same ($L_{s1X} \approx L_{s2X}$, $L_{s5} \approx L_{s6}$ – see Figure 3).
- It is important, to have a low-inductance connection between all paralleled IGBT modules (except for the load conditions L_{s5} and L_{s6}). Differences will cause collector current and collector-emitter voltage asymmetries. These in turn will lead to dynamic emitter potential differences between IGBTs and cause common mode current to flow between gate drivers. This will also lead to asymmetric switching losses between the IGBT modules. In the worst-case, symmetry can cause false switching. Solutions are provided later.
- Minimize the DC-link loop-inductance of the converter.

Increasing the output inductances L_{s5} and L_{s6} helps to reduce dynamic current imbalance during commutation as they limit the current difference between outputs when output voltages are different.

It should be noted that a double-pulse test typically results in higher imbalance than seen in continuous converter operation which benefits from thermal balancing effects.

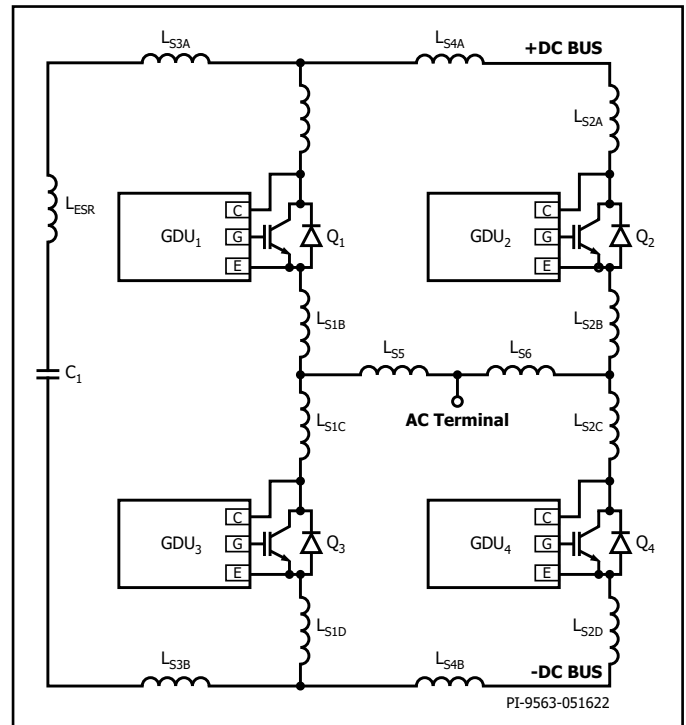

Figure 3. Half-Bridge Topology Showing Stray Inductances.

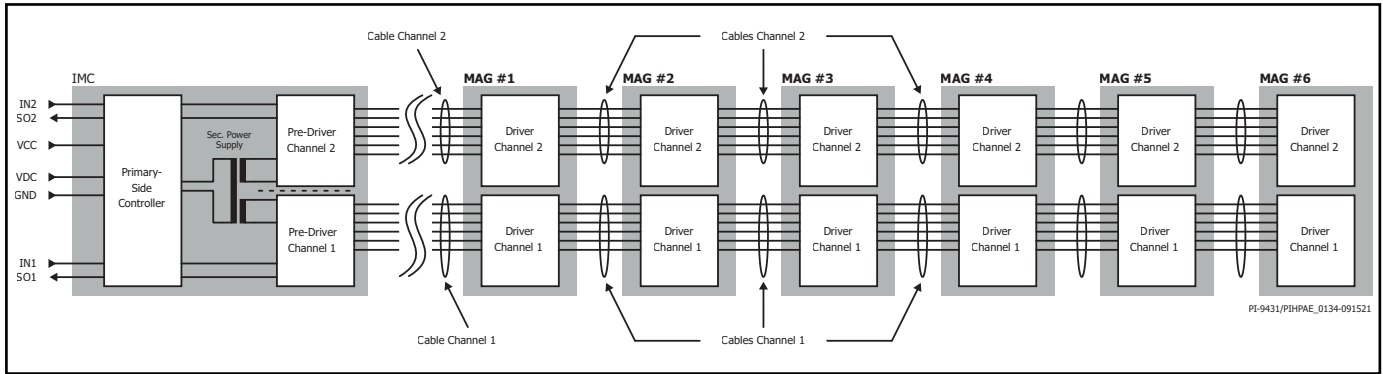

Figure 4. Block Diagram of a SCALE-iFlex LT IMC with 6 MAGs in Parallel.

Optimizing Mechanical Layout

Current distribution among paralleled IGBTs is influenced by small changes in the mechanical set-up. Both IGBT and diode current sharing are affected by the parasitic impedances of the AC and DC terminals.

To investigate the effect of the DC and AC mechanical connections on the parallel operation during a double pulse test, we will assume that the gate drivers and IGBT modules have no impact (Note that for a real system, all the parasitic gate driver impedances need to be considered). It is recommended that during design optimization, each parameter is changed separately to determine its effect. The following guidelines help achieving best performance:

1. Static current sharing is mainly influenced by the AC bar connection and should be optimized first. The type and position of the load inductor can have a significant impact on static current sharing.
2. The design of the AC bus bar and the connection of the load connector (and associated parasitics) do not have a significant impact on the switching symmetry of the IGBTs at turn-on. So the influence of parasitic impedances on the AC side are not the key factor for dynamic current sharing during turn-on.
3. The DC side has a high impact on the dynamic current symmetry at turn-on.
4. The torque of the IGBT connector screws may have a significant impact on dynamic current sharing during switching. Follow the recommended mounting torques for the IGBT modules.

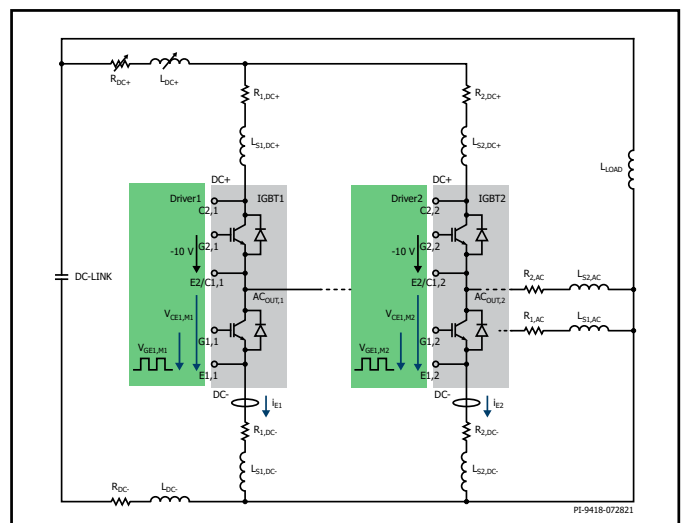

Figure 5. Impact of Power Loop Set-up on Current Sharing During a Double Pulse Test.

Paralleling with SCALE-iFlex and SCALE-iFlex LT Gate Drivers' Families

SCALE-iFlex and SCALE-iFlex LT enable easy paralleling of IGBT power modules and provide high flexibility and system scalability while minimizing development effort.

Both gate driver families consist of an Isolated Master Control (IMC) unit which supports a number of Module Adapted Gate Drivers (MAGs) together with accompanying cable sets. Figure 4 shows a block diagram of an IMC working with 6 parallel MAGs.

The IMC is designed for the operation of power modules with a blocking voltage of up to 3300 V. The MAGs are optimized for different power modules and chip technologies in voltage classes up to 3300 V.

The different MAG structures are dedicated to specific power modules. For more details, refer to their respective data sheets. Please contact Power Integrations to discuss other module requirements.

It should be noted that the number of modules that can be connected in parallel depends on the selected driver family and the IGBT module used. This information is provided in the data sheet.

Paralleling Instructions for Main and Peripheral SCALE-2 Drivers

To reduce common-mode noise and circulating current between the emitters of parallel-connected IGBTs, the following recommendations are provided:

1. Implement paralleling of the IGBT modules using one DC-link busbar. The emitters of all paralleled IGBTs should be connected to each other in such a way as to ensure lowest possible inductance and resistance. This is shown in Figure 6 (a).

2. Avoid common-mode noise by ensuring that the connection cable is separated from the next conducting surface by at least 30 mm – as shown in Figure 6(b). This reduces common-mode capacitance.
3. If needed, common-mode currents between main and peripheral drivers (or between peripheral gate drivers) can be reduced by adding ferrite inductors to the paralleling cables. If used it is important to ensure that these inductors do not saturate. Correctly select the appropriate material and core size. Increasing the number of turns around the core increases the inductance of the ferrite and reduces the likelihood of saturation.

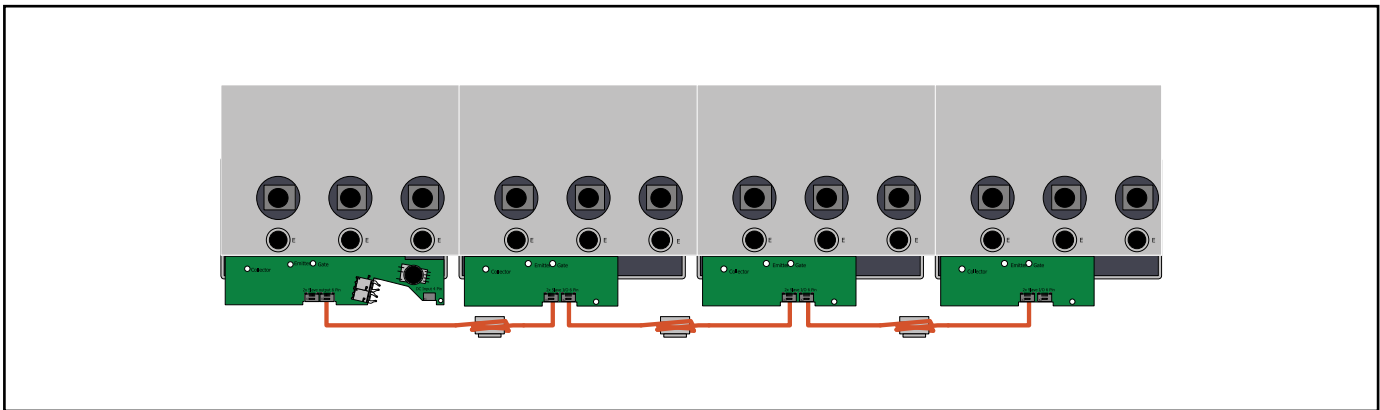

(a)

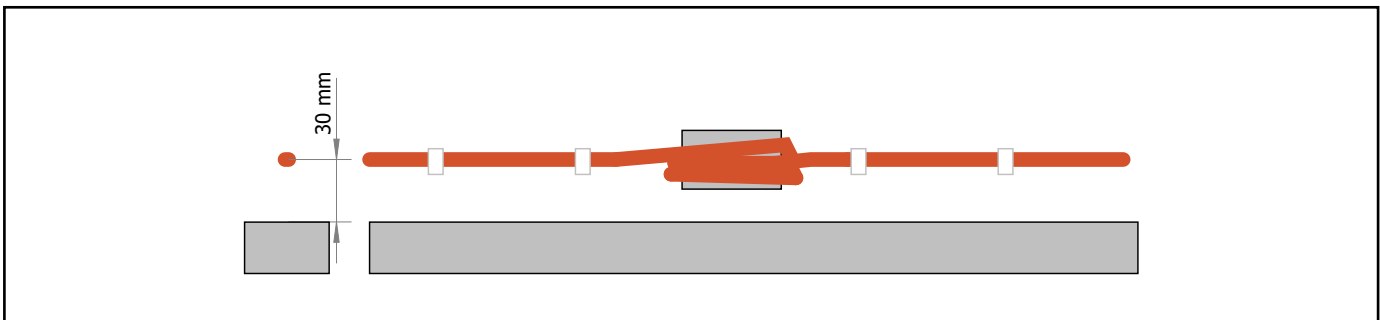

(b)

Figure 6. Parallel Set-up Consideration for Main and Peripheral SCALE-2 Drivers (a) One Busbar Connecting all IGBTs (b) Ferrite Core Added to Connection Cables with Plastic "L-Stand-off" for Connection Cables and Ferrites.

Revision	Notes	Date
A	Initial release.	07/22

For the latest updates, visit our website: www.power.com

Power Integrations reserves the right to make changes to its products at any time to improve reliability or manufacturability. Power Integrations does not assume any liability arising from the use of any device or circuit described herein. POWER INTEGRATIONS MAKES NO WARRANTY HEREIN AND SPECIFICALLY DISCLAIMS ALL WARRANTIES INCLUDING, WITHOUT LIMITATION, THE IMPLIED WARRANTIES OF MERCHANTABILITY, FITNESS FOR A PARTICULAR PURPOSE, AND NON-INFRINGEMENT OF THIRD PARTY RIGHTS.

Patent Information

The products and applications illustrated herein (including transformer construction and circuits external to the products) may be covered by one or more U.S. and foreign patents, or potentially by pending U.S. and foreign patent applications assigned to Power Integrations. A complete list of Power Integrations patents may be found at www.power.com. Power Integrations grants its customers a license under certain patent rights as set forth at www.power.com/ip.htm.

Life Support Policy

POWER INTEGRATIONS PRODUCTS ARE NOT AUTHORIZED FOR USE AS CRITICAL COMPONENTS IN LIFE SUPPORT DEVICES OR SYSTEMS WITHOUT THE EXPRESS WRITTEN APPROVAL OF THE PRESIDENT OF POWER INTEGRATIONS. As used herein:

1. A Life support device or system is one which, (i) is intended for surgical implant into the body, or (ii) supports or sustains life, and (iii) whose failure to perform, when properly used in accordance with instructions for use, can be reasonably expected to result in significant injury or death to the user.
2. A critical component is any component of a life support device or system whose failure to perform can be reasonably expected to cause the failure of the life support device or system, or to affect its safety or effectiveness.

Power Integrations, the Power Integrations logo, CAPZero, ChiPhy, CHY, DPA-Switch, EcoSmart, E-Shield, eSIP, eSOP, HiperLCS, HiperPLC, HiperPFS, HiperTFS, InnoSwitch, Innovation in Power Conversion, InSOP, LinkSwitch, LinkZero, LYTSwitch, SENZero, TinySwitch, TOPSwitch, PI, PI Expert, PowiGaN, SCALE, SCALE-1, SCALE-2, SCALE-3 and SCALE-iDriver, are trademarks of Power Integrations, Inc. Other trademarks are property of their respective companies. ©2022, Power Integrations, Inc.

Power Integrations Worldwide Sales Support Locations

World Headquarters

5245 Hellyer Avenue
San Jose, CA 95138, USA
Main: +1-408-414-9200
Customer Service:
Worldwide: +1-65-635-64480
Americas: +1-408-414-9621
e-mail: usasales@power.com

China (Shanghai)

Rm 2410, Charity Plaza, No. 88
North Caoxi Road
Shanghai, PRC 200030
Phone: +86-21-6354-6323
e-mail: chinasales@power.com

China (Shenzhen)

17/F, Hivac Building, No. 2, Keji Nan
8th Road, Nanshan District,
Shenzhen, China, 518057
Phone: +86-755-8672-8689
e-mail: chinasales@power.com

Germany

(AC-DC/LED/Motor Control Sales)
Einsteinring 24
85609 Dornach/Aschheim
Germany
Tel: +49-89-5527-39100
e-mail: eurosales@power.com

Germany (Gate Driver Sales)

HellwegForum 3
59469 Ense
Germany
Tel: +49-2938-64-39990
e-mail: igbt-driver.sales@power.com

India

#1, 14th Main Road
Vasanthanagar
Bangalore-560052 India
Phone: +91-80-4113-8020
e-mail: indiasales@power.com

Italy

Via Milanese 20, 3rd. Fl.
20099 Sesto San Giovanni (MI) Italy
Phone: +39-024-550-8701
e-mail: eurosales@power.com

Japan

Yusen Shin-Yokohama 1-chome Bldg.
1-7-9, Shin-Yokohama, Kohoku-ku
Yokohama-shi,
Kanagawa 222-0033 Japan
Phone: +81-45-471-1021
e-mail: japansales@power.com

Korea

RM 602, 6FL
Korea City Air Terminal B/D, 159-6
Samsung-Dong, Kangnam-Gu,
Seoul, 135-728, Korea
Phone: +82-2-2016-6610
e-mail: koreasales@power.com

Singapore

51 Newton Road
#19-01/05 Goldhill Plaza
Singapore, 308900
Phone: +65-6358-2160
e-mail: singaporesales@power.com

Taiwan

5F, No. 318, Nei Hu Rd., Sec. 1
Nei Hu Dist.
Taipei 11493, Taiwan R.O.C.
Phone: +886-2-2659-4570
e-mail: taiwansales@power.com

UK

Building 5, Suite 21
The Westbrook Centre
Milton Road
Cambridge
CB4 1YG
Phone: +44 (0) 7823-557484
e-mail: eurosales@power.com